

## GRIT WASHER

### Sand Separation & Cleaning

#### DESCRIPTION

EQUIP GRIT is used for the separation and cleaning of sandy material from wastewater. These machines consist of a conical decantation hopper, provided with an agitation system that give to sandy waste water a rotational movement; this rotation facilitates the sedimentation process and, at the same time, keeps in suspension the organic matters.

The hopper's bottom is fed with clean water that creates a counterflow that removes the organic material which is then evacuated from a pipe placed at the upper side of the hopper.



The washed sands are removed from the bottom of the hopper by a shafted screw conveyor, while the output cleaned water outflows from a pipe placed at the top of the hopper.

The water enters the hopper through the inlet scroll; the volume is kept in motion by the agitator central that a rotational movement, whose purpose is to facilitate the sedimentation of the sand and at the same time to maintain suspension of the organic material.

#### BENEFITS

- Equipment 2 in 1
- Residual Organic Content:  $\leq 5\%$
- Grit separation:  $\geq 90\%$  for particles up to  $200\ \mu\text{m}$
- Trough Protection with HDPE liner for the screw

## GRIT WASHER

### Sand Separation & Cleaning

The sand, on its way towards the bottom is further washed clean water fed in countercurrent, to then be extracted from the cochlea. The water countercurrent also has the task of facilitating the ascent of the organic substances, that are then evacuate at regular intervals by a special exhaust pipe. The clarified water is instead evacuated by a second conduit placed in the upper part of the conical hopper. The constant rotational motion of the water mass allows the sand to pass from the hopper to the discharge screw, which conveys it to the exit.

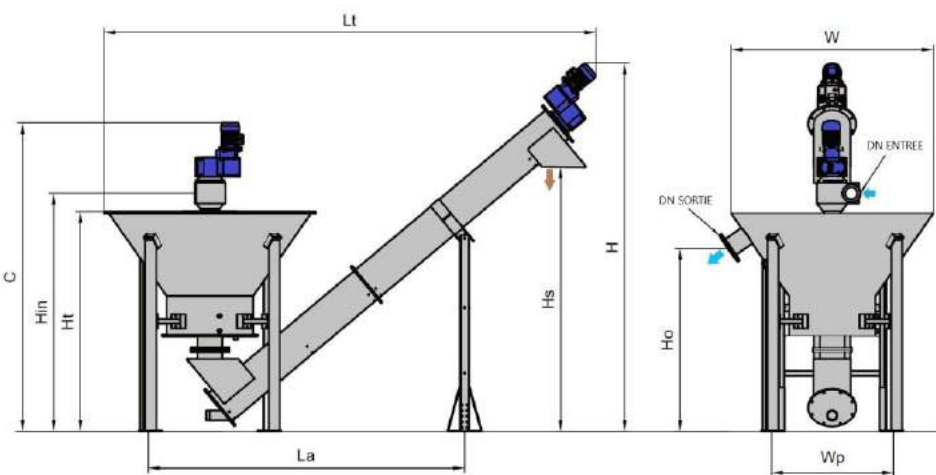
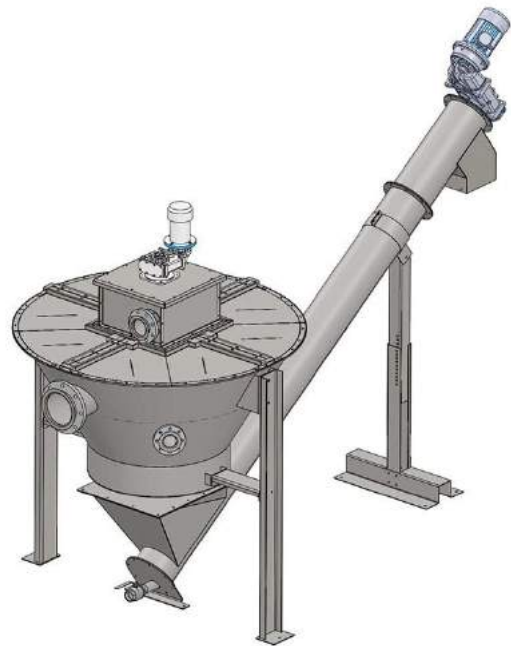

#### FEATURES

- Screw: stainless steel 304/316
- Structure: stainless steel 304/316
- Grit:  $\geq 90\%$  for particles up to  $200 \mu\text{m}$
- Residual Organic Content:  $\leq 5\%$
- Inlet Flow Rate: up to  $90 \text{ m}^3/\text{h}$

MODEL	Lt	H	La	Wp	W	C	Ht	Hin	Ho	Hs	INLET	OUTLET	Flow	Water capacity	Sand removing capacity
	mm											PN10	m <sup>3</sup> /h	m <sup>3</sup>	m <sup>3</sup> /h
Equip Grit 30	4500	3300	3000	1100	1900	2750	1950	2100	1600	2400	DN100	DN150	30	0,91	0,4
Equip Grit 60	5200	3700	3100	1900	2100	3000	2300	2500	2000	2800	DN200	DN200	60	1,93	0,4
Equip Grit 90	5500	3700	3100	1900	2300	3100	2320	2500	2000	2800	DN200	DN200	90	2,92	0,4